

2500/406

NATIONAL
QUALIFICATIONS
2002

THURSDAY, 9 MAY
2.45 PM – 4.05 PM

MATHEMATICS
STANDARD GRADE
Credit Level
Paper 2

- 1 You may use a calculator.
- 2 Answer as many questions as you can.
- 3 Full credit will be given only where the solution contains appropriate working.
- 4 Square-ruled paper is provided.



FORMULAE LIST

The roots of $ax^2 + bx + c = 0$ are $x = \frac{-b \pm \sqrt{(b^2 - 4ac)}}{2a}$

Sine rule: $\frac{a}{\sin A} = \frac{b}{\sin B} = \frac{c}{\sin C}$

Cosine rule: $a^2 = b^2 + c^2 - 2bc \cos A$ or $\cos A = \frac{b^2 + c^2 - a^2}{2bc}$

Area of a triangle: Area = $\frac{1}{2}ab \sin C$

Standard deviation: $s = \sqrt{\frac{\sum(x - \bar{x})^2}{n-1}} = \sqrt{\frac{\sum x^2 - (\sum x)^2/n}{n-1}}$, where n is the sample size.

1. A spider weighs approximately 19.06×10^{-5} kilograms.
A humming bird is 18 times heavier.
Calculate the weight of the humming bird.
Give your answer **in scientific notation**.

2. A microwave oven is sold for £150.
This price includes VAT at 17.5%.
Calculate the price of the microwave oven **without** VAT.

3. Solve the equation

$$2x^2 + 3x - 7 = 0.$$

Give your answers **correct to 1 decimal place**.

[Turn over

KU	RE
2	
3	
4	

4. A TV signal is sent from a transmitter T, via a satellite S, to a village V, as shown in the diagram. The village is 500 kilometres from the transmitter.

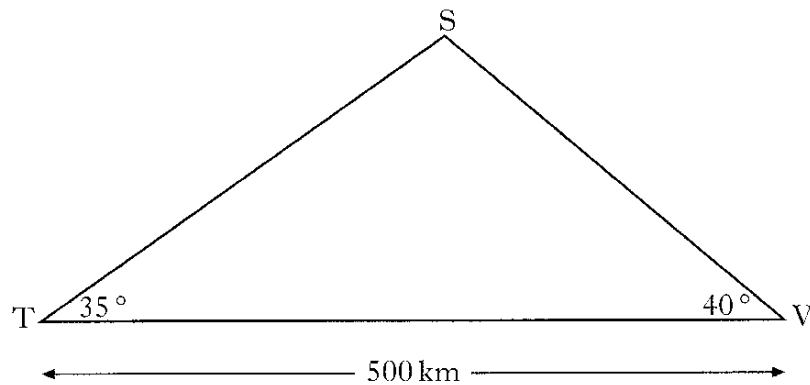

The signal is sent out at an angle of 35° and is received in the village at an angle of 40° .

Calculate the height of the satellite above the ground.

5

5. A feeding trough, 4 metres long, is prism-shaped.

The uniform cross-section is made up of a rectangle and semi-circle as shown below.

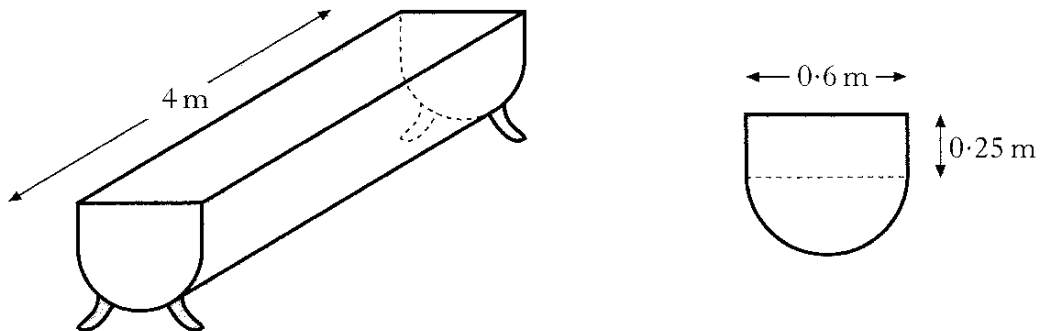

Find the volume of the trough, **correct to 2 significant figures**.

5

6. An oil tank has a circular cross-section of radius 2.1 metres.
It is filled to a depth of 3.4 metres.

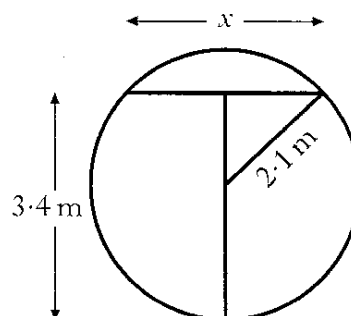
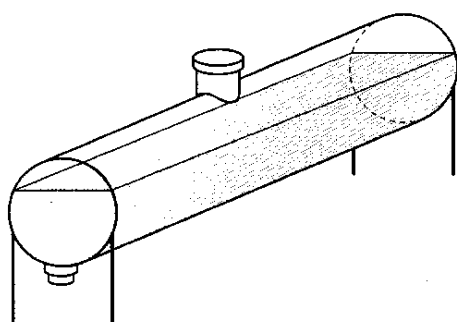

- (a) Calculate x , the width in metres of the oil surface.
(b) What other depth of oil would give the same surface width?

3

1

7. A coffee shop blends its own coffee and sells it in one-kilogram tins.
One blend consists of two kinds of coffee, Brazilian and Colombian, in the ratio 2 : 3.
The shop has 20 kilograms of Brazilian and 25 kilograms of Colombian in stock.
What is the **maximum** number of one-kilogram tins of this blend which can be made?

3

[Turn over

KU	RE
	3
	1
	1
	1
	3

8. The diagram shows part of the graph of $y = \sin x^\circ$.

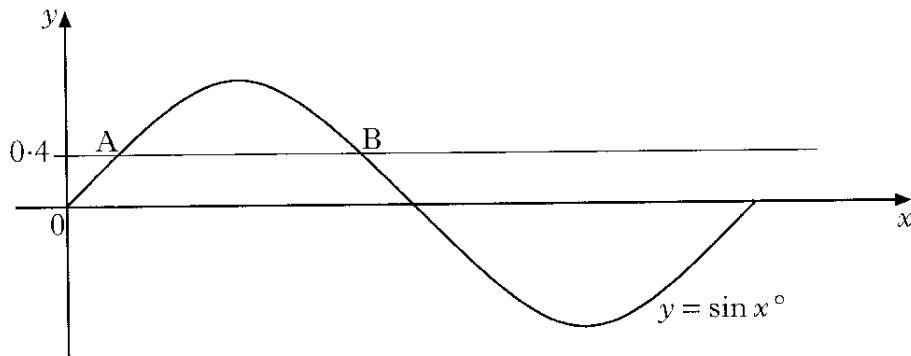

The line $y = 0.4$ is drawn and cuts the graph of $y = \sin x^\circ$ at A and B.
Find the x -coordinates of A and B.

9. Esther has a new mobile phone and considers the following daily rates.

Easy Call

25 pence per minute for the first 3 minutes

5 pence per minute **after** the first three minutes

Green Call

40 pence per minute for the first 2 minutes

2 pence per minute **after** the first two minutes

- (a) For Easy Call, find the cost of ten minutes in a day.
- (b) For Easy Call, find a formula for the cost of “m” minutes in a day, $m > 3$.
- (c) For Green Call, find a formula for the cost of “m” minutes in a day, $m > 2$.
- (d) Green Call claims that its system is cheaper.

Find **algebraically** the least number of minutes (to the nearest minute) which must be used each day for this claim to be true.

10. A weight on the end of a string is spun in a circle on a smooth table.

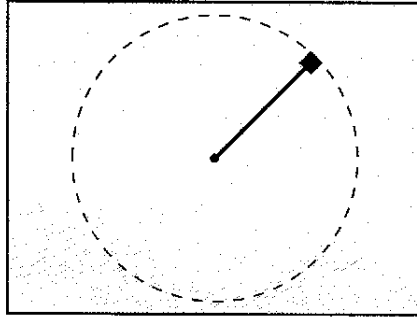

The tension, T , in the string varies directly as the square of the speed, v , and inversely as the radius, r , of the circle.

- (a) Write down a formula for T in terms of v and r .
- (b) The speed of the weight is multiplied by 3 and the radius of the string is halved.
What happens to the tension in the string?

1

2

11. (a) Solve the equation

$$2^n = 32.$$

- (b) A sequence of numbers can be grouped and added together as shown.

The sum of 2 numbers: $(1 + 2) = 4 - 1$

The sum of 3 numbers: $(1 + 2 + 4) = 8 - 1$

The sum of 4 numbers: $(1 + 2 + 4 + 8) = 16 - 1$

Find a **similar** expression for the sum of 5 numbers.

- (c) Find a formula for the sum of the first n numbers of this sequence.

1

1

2

[Turn over for Question 12 on Page eight

KU	RE

12. A metal beam, AB, is 6 metres long.

It is hinged at the top, P, of a vertical post 1 metre high.

When B touches the ground, A is 1.5 metres above the ground, as shown in Figure 1.

Figure 1

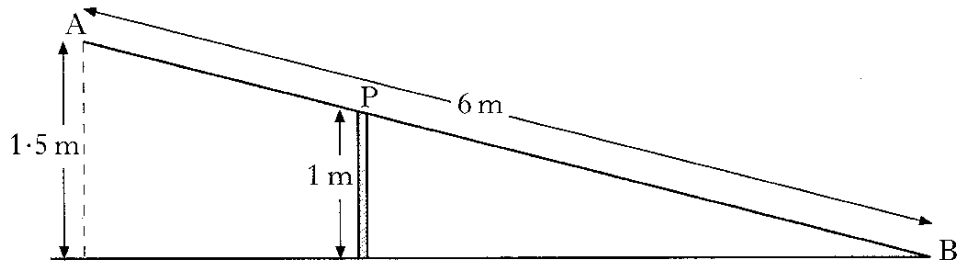

When A comes down to the ground, B rises, as shown in Figure 2.

Figure 2

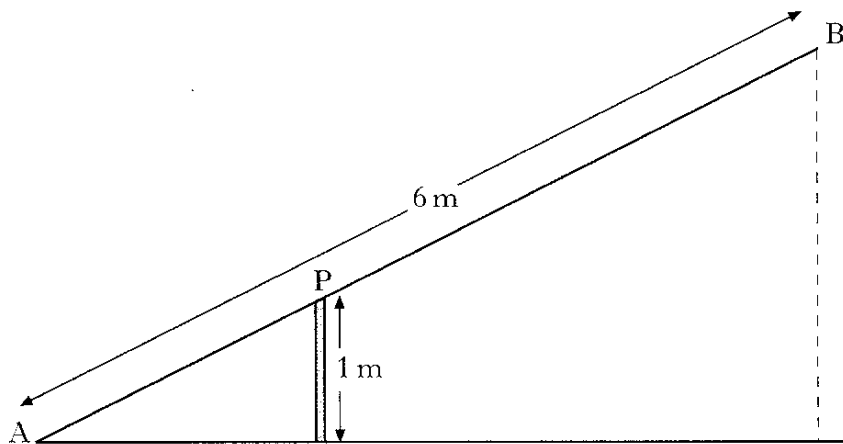

By calculating the length of AP, or otherwise, find the height of B above the ground.

Do not use a scale drawing.

[END OF QUESTION PAPER]