



MATHEMATICS

N5

Final Exam

Model Papers A-F

FORMULAE LIST

The roots of $ax^2 + bx + c = 0$ are $x = \frac{-b \pm \sqrt{b^2 - 4ac}}{2a}$

Sine Rule: $\frac{a}{\sin A} = \frac{b}{\sin B} = \frac{c}{\sin C}$

Cosine Rule: $a^2 = b^2 + c^2 - 2bc \cos A$ or $\cos A = \frac{b^2 + c^2 - a^2}{2bc}$

Area of a triangle: $A = \frac{1}{2} ab \sin C$

Volume of a sphere: $V = \frac{4}{3} \pi r^3$

Volume of a cone: $V = \frac{1}{3} \pi r^2 h$

Volume of a pyramid: $V = \frac{1}{3} Ah$

Standard deviation: $s = \sqrt{\frac{\sum (x - \bar{x})^2}{n - 1}} = \sqrt{\frac{\sum x^2 - (\sum x)^2 / n}{n - 1}}$

where n is the sample size

Paper A (Non-Calculator)

1. Evaluate: $2\frac{4}{5} \div \frac{7}{10}$
2. Multiply out the brackets and collect like terms: $(3x+1)(x^2-2x+3)$
3. Two forces acting on a rocket are represented by vectors **a** and **b**.

$$a = \begin{pmatrix} 3 \\ -1 \\ -5 \end{pmatrix} \text{ and } b = \begin{pmatrix} -1 \\ 8 \\ 6 \end{pmatrix}$$

Calculate $|a+b|$, the magnitude of the resultant force.

Express your answer as a surd in its simplest form.

4. Solve the equation: $6x^2 + x - 2 = 0$.
5. Express $\frac{8}{\sqrt{10}}$ with a rational denominator in its simplest form.
6. Teams in a quiz answer questions on film and sport.

This scattergraph shows the scores of some of the teams.

A line of best fit is drawn as shown.

- (a) Find the equation of this straight line.
- (b) Use the equation to estimate the Sport Score for a team with a Film Score of 7.

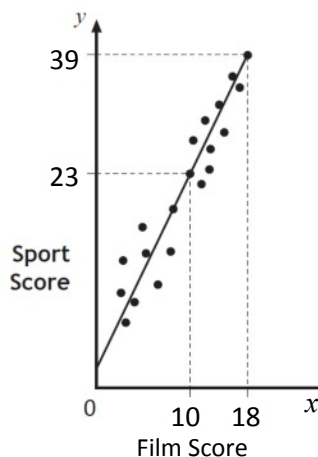

7. Change the subject of the formula $a = \frac{b^2c}{4}$ to b .

8. (a) Multiply out the brackets and simplify: $x^{\frac{1}{2}}\left(x^{\frac{5}{2}} + x^{-\frac{1}{2}}\right)$.
- (b) Find the exact value of this expression when $x = 4$.
9. A parabola has equation $y = x^2 - 6x + 14$.
- (a) Write the equation in the form $y = (x - p)^2 + q$.
- (b) Sketch the graph of $y = x^2 - 6x + 14$, showing the coordinates of the turning point and the point of intersection with the y-axis.
10. Colin and Jane visit a music shop. Colin buys 3 CDs and 2 DVDs. The total cost of this is £33.
- (a) Write down an equation to illustrate this information.
- (b) Jane buys 4 CDs and 3 DVDs.
- The total cost of this is £47.
- Write down an equation to illustrate this information.
- (c) Find the cost of a CD and the cost of a DVD.
11. Express: $\frac{3}{x+2} - \frac{2}{x-3}$, $x \neq -2, x \neq 3$ as a single fraction in its simplest form.

12. A cylindrical pipe has water in it as shown.
- The depth of the water at the deepest point is 4 centimetres.
- The width of the water surface, AB, is 14 centimetres.
- The radius of the pipe is r centimetres. The distance from the centre, O, of the pipe to the water surface is x centimetres.

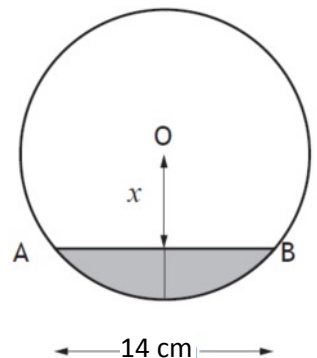

- (a) Write down an expression for x in terms of r .
- (b) Calculate r , the radius of the pipe.

Paper A (Calculator)

- Beth normally cycles a total distance of 48 miles per week.
She increases her distance by 12% each week for the next three weeks.
How many miles will she cycle in the third week?
- There are 4×10^4 platelets per millilitre of blood.
On average, a person has 6.2 litres of blood.
On average, how many platelets does a person have in their blood?
Give your answer in scientific notation.

- In the diagram, OABCDE is a regular hexagon with centre M.

Vectors **a** and **b** are represented by \overrightarrow{OA} and \overrightarrow{OB} respectively.

- Express \overrightarrow{AB} in terms of **a** and **b**.
- Express \overrightarrow{OC} in terms of **a** and **b**.

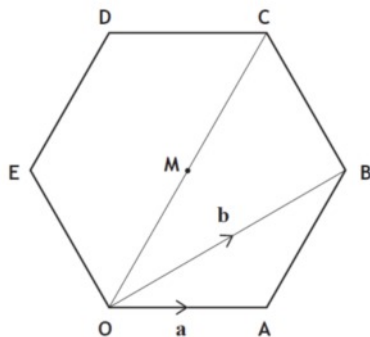

- The graph with equation $y = kx^2$ is shown.
The point (3, -27) lies on the graph.
Determine the value of k .

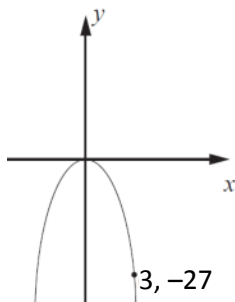

- In triangle ABC, $AB = 9$ cm,
 $AC = 4$ cm and
angle $BAC = 74^\circ$.
Calculate the length of BC.

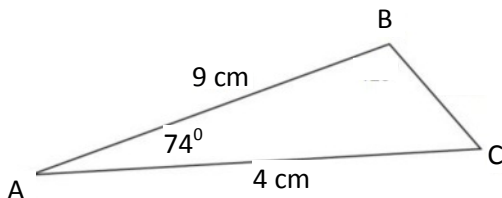

6. A child's toy is in the shape of a hemisphere with a cone on top, as shown in the diagram.

The toy is 10 centimetres wide and 21 centimetres high.

Calculate the volume of the toy. Give your answer correct to 2 significant figures.

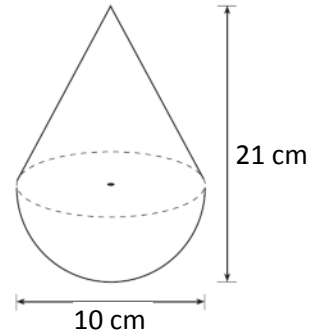

7. This year Adèle paid £288 for T in the Park tickets.

This is an increase of 20% on last year's payment.

How much did Adèle pay last year?

8. A frozen food company uses machines to pack sprouts into bags.

A sample of six bags is taken from Machine A and the number of sprouts in each bag is counted.

The results are shown: 24 29 27 23 28 25

(a) Calculate the mean and standard deviation of this sample.

(b) Another sample of six bags is taken from Machine B.

This sample has a mean of 24 and a standard deviation of 2.8.

Write down two valid comparisons between the samples.

9. Screenwash is available in two different sized bottles, 'Mini' and 'Maxi'.

The bottles are mathematically similar.

Calculate the volume of the 'Maxi' bottle.

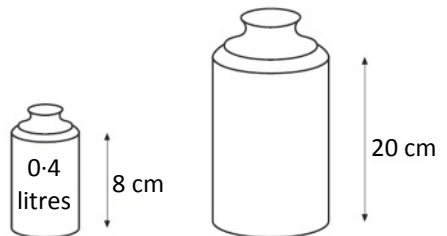

10. Part of the graph of $y = a\cos x^\circ + b$ is shown below.

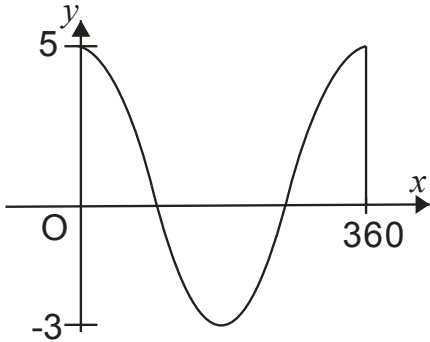

- (a) Write down the values of a and b .
- (b) Calculate the x -coordinates of the points where the graph cuts the x -axis.

11. A cone is formed from a paper circle with a sector removed as shown.
The radius of the paper circle is 30 centimetres.
Angle AOB is 125° .

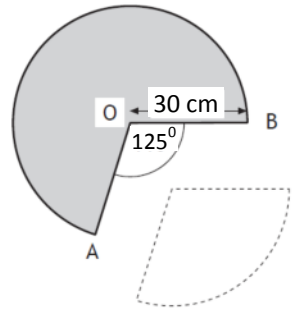

- (a) Calculate the area of the sector removed from the circle.
- (b) Calculate the circumference of the base of the cone.
12. Find the range of values of p such that the equation $px^2 - 4x + 4 = 0$, $p \neq 0$, has no real roots.

Paper B (Non-Calculator)

1. Evaluate: $5\frac{1}{2} - 2\frac{3}{5}$.

2. Expand and simplify: $(2x - 3)(2x^2 - 5x + 2)$.

3. Change the subject of the formula to q : $V = \frac{\sqrt{q}}{r}$.

4. The diagram shows a tiling of congruent triangles.

Vectors \mathbf{u} and \mathbf{v} are represented by \overrightarrow{AB} and \overrightarrow{AF} respectively.

(a) Express \overrightarrow{AD} in terms of \mathbf{u} and \mathbf{v} .

(b) Express \overrightarrow{CE} in terms of \mathbf{u} and \mathbf{v} .

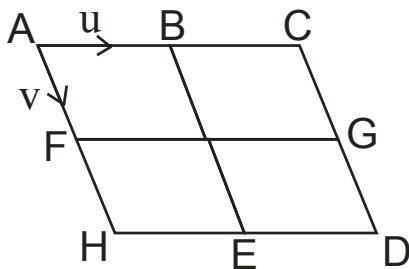

5. In the diagram

- O is the centre of the circle
- PQ is the diameter
- PQR is a straight line
- RS is a tangent to the circle at S
- Angle QPS is 24°

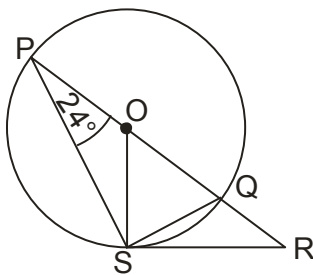

Calculate the size of angle QRS.

6. Express $\frac{2y^2 - 6y}{y^2 + y - 2}$ in its simplest form.

7. Evaluate $8^{\frac{2}{3}}$.

8. Simplify $\frac{2}{m} + \frac{3}{m-1}$.

9. The diagram shows part of the graph of

$$y = 8 + 2x - x^2.$$

(a) Find the coordinates of A and B

(a) State the equation of the axis of symmetry of the graph.

(b) Hence, find the maximum value of

$$y = 8 + 2x - x^2.$$

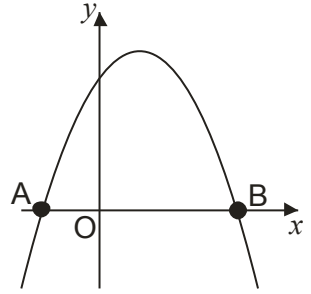

10. The graph below shows two straight lines

- $y = 3x - 2$
- $x + 2y = 10$

The lines intersect at the point P.

Find, **algebraically**, the coordinates of P.

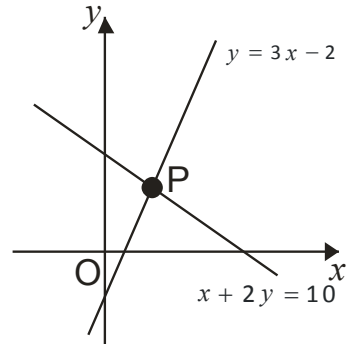

11. Part of the graph of $y = a \cos bx^\circ$ is shown in the diagram.

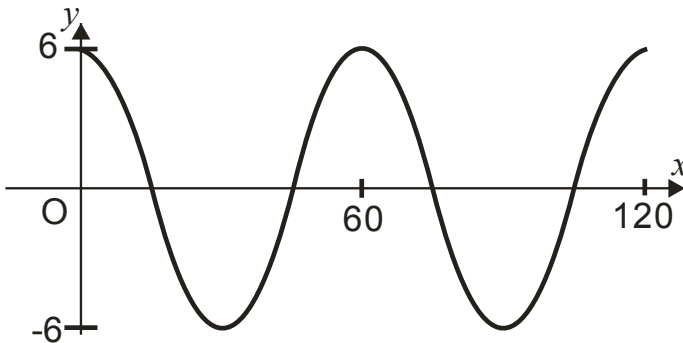

State the values of a and b .

12. In the triangle ABC, show that $\cos B = \frac{11}{16}$.

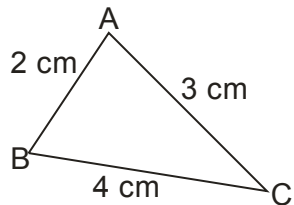

13. The rectangle has length $4\sqrt{3}$ centimetres and breadth $2\sqrt{6}$ centimetres.

Calculate the area of the rectangle.

Express your answer as a surd in its simplest form.

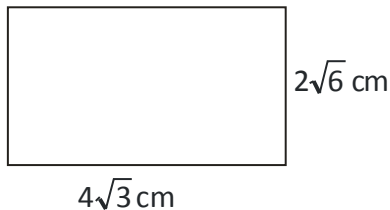

14. Prove that the roots of the equation $2x^2 + 3x - 2 = 0$ are real and rational.

Paper B (Calculator)

1. Alistair buys an antique chair for £450.

It is expected to increase in value at the rate of 6.3% each year.

How much is it expected to be worth in 4 years?

2. A footballer scored the following number of goals in a series of tournaments.

12 14 10 9 4 11 3

(a) For this sample calculate the mean and standard deviation.

The following season the team appoints a new coach. A similar series of matches produces a mean of 10 and a standard deviation of 2.48.

(b) Make two valid comparisons about the performance of the team under the new coach.

3. The diagram shows a cuboid OPQRSTUV relative to the coordinate axes.

P is the point (8, 0, 0), Q is (8, 6, 0) and U is (8, 6, 4).

M is the midpoint of OR.

N is the point on UQ such that $UN = \frac{1}{4}UQ$.

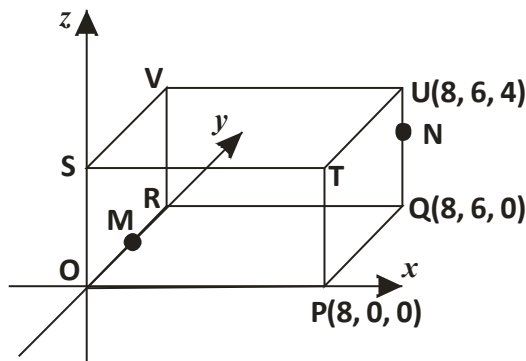

State the coordinates of M and N.

4. Find the equation of the straight line shown in the diagram.

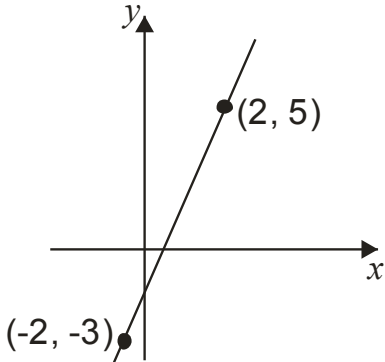

5. A spiral staircase is being designed.

Each step is made from a sector of a circle as shown.

The radius is 1.4 metres.

Angle BAC is 46° .

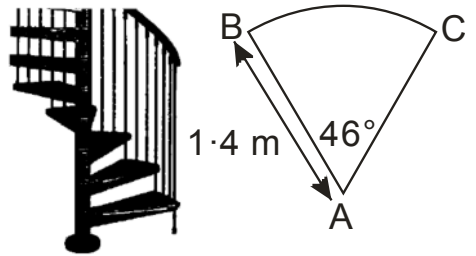

For the staircase to pass safety regulations, the arc BC must be at least 0.8 metres. Will the staircase pass safety regulations?

6. A glass ornament is in the shape of a cone partly filled with coloured water.

The cone is 18 centimetres high and has a base diameter 25 centimetres.

The water is 14 centimetres deep and measures 12 centimetres across the top.

What is the volume of the water?

Give your answer correct to 2 significant figures.

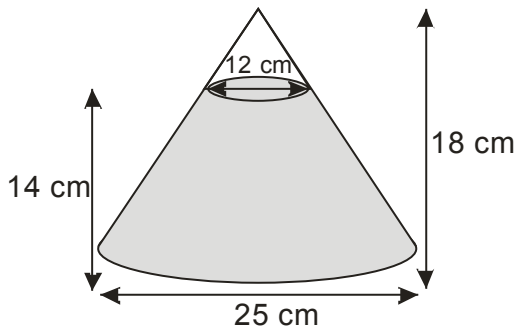

7. The price for Paul's summer holiday is £892.50.

The price includes a 5% booking fee.

What is the price of his holiday without the booking fee?

8. A heavy metal beam, AB, rests against a vertical wall as shown.

The length of the beam is 9 metres and it makes an angle of 62° with the ground.

A cable, CB, is fixed to the ground at C and is attached to the top of the beam at B.

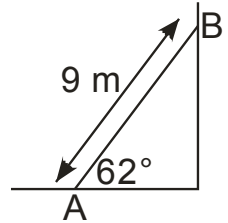

The cable makes an angle of 26° with the ground.

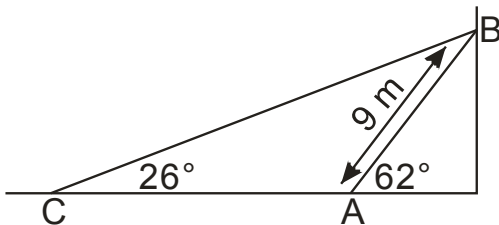

Calculate the length of cable CB.

9. A necklace is made of beads which are mathematically similar.

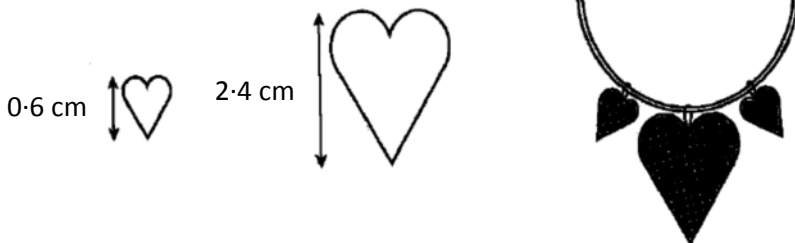

The height of the smaller bead is 0.6 centimetres and its area is 0.9 square centimetres. The height of the larger bead is 2.4 centimetres. Find the area of the larger bead.

10. Paving stones are in the shape of a rhombus.

The side of each rhombus is 50 centimetres long.

The obtuse angle is 112° .

Find the area of one paving stone.

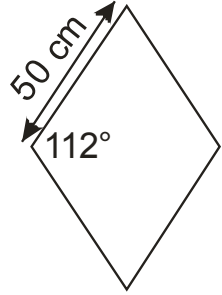

11. $f(x) = 4\sin x$, $0 \leq x \leq 360$.

(a) Find $f(270)$

(b) If $f(t) = 0.8$, find two possible values of t .

12. A tanker delivers oil to garages.

The tanker has a circular cross-section as shown.

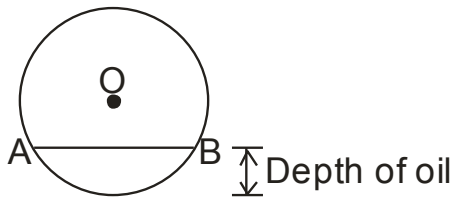
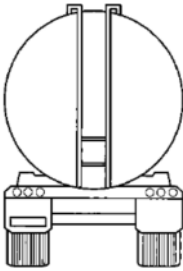

The radius of the circle, OA is 1.4 metres.

The width of the surface of the oil, represented by AB in the diagram, is 2.0 metres.

Calculate the depth of oil in the tanker.

13. Triangles PQR and STU are mathematically similar.

The scale factor is 2 and PR corresponds to SU .

(a) Show that $x^2 - 8x + 7 = 0$.

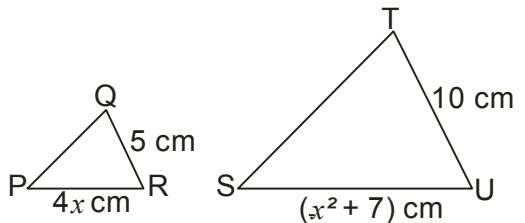

(b) Given that QR is the shortest side of triangle PQR , find the value of x .

Paper C (Non-Calculator)

1. Evaluate: $\frac{3}{4} \div 2\frac{1}{8}$.
2. Factorise fully: $3a^2 - 12$.
3. Given that $f(x) = 7 - x^2$, evaluate $f(-2)$.
4. Solve the equation $2x + 3 = \frac{x-2}{3}$.
5. Express $\sqrt{8} + \sqrt{18} - \sqrt{2}$ as a surd in its simplest form.
6. Express $x^2 + 8x + 7$ in the form $(x + p)^2 + q$.
7. Alan is taking part in a quiz. He is awarded x points for each correct answer and y points for each wrong answer. During the quiz, Alan gets 24 questions correct and 6 wrong. He scores 60 points.
 - (a) Write down an equation in x and y which satisfies the above condition.
Helen also takes part in the quiz. She gets 20 questions correct and 10 wrong. She scores 40 points.
 - (b) Write down a second equation in x and y which satisfies this condition.
 - (c) Calculate the score for David who gets 17 correct and 13 wrong.
8. A circle, centre O is shown.

In the circle

- PB is a diameter
- CR is a tangent to the circle at point P
- Angle BCP is 52°

Calculate the size of angle EPR .

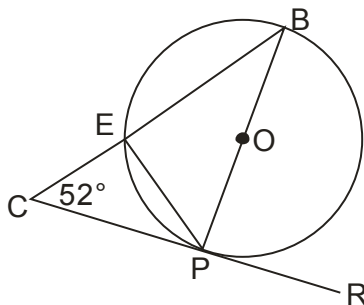

9. The graph shows the relationship between the history and geography marks of a class of students.

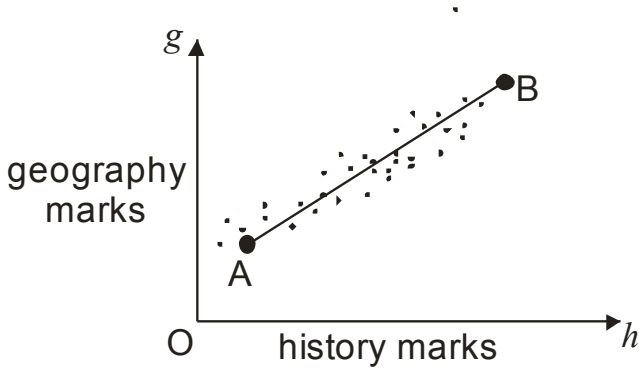

A best fitting straight line, AB has been drawn.

Point A represents 11 marks for history and 10 marks for geography.

Point B represents 71 marks for history and 50 marks for geography.

Find the equation of the straight line AB in terms of h and g .

10. A kite PQRS is shown.

The diagonals of the kite intersect at T.

$PT = 3TR$.

\overrightarrow{PR} represents vector **a**.

\overrightarrow{QS} represents vector **b**.

Express \overrightarrow{PS} in terms of **a** and **b**.

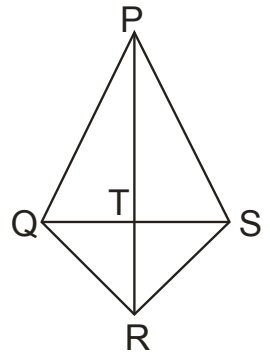

11. Express $\frac{a^{\frac{3}{2}} \times a^{\frac{1}{2}}}{a}$ in its simplest form.

12. In the triangle ABC,

- AC = 4 centimetres
- BC = 8 centimetres
- Angle BAC = 150°

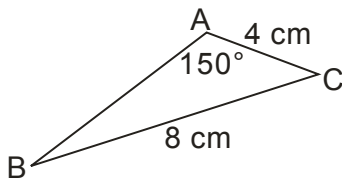

Given that $\sin 30^\circ = \frac{1}{2}$, show that $\sin B = \frac{1}{4}$.

13. Express $\frac{3m^2}{6} \div \frac{m}{2}$ as a fraction in its simplest form.

14. Prove that $\frac{\sin^2 A}{1 - \sin^2 A} = \tan^2 A$.

Paper C (Calculator)

1. If $P=2QR$, find the value of P when $Q=2.4\times 10^{-7}$ and $R=3.2\times 10^5$.

Give your answer in scientific notation

2. Expand fully and simplify $x(x-2)^2$.

3. A sector of a circle, centre O , is shown.

The radius of the circle is 4.2 metres.

Angle AOB is 73° . Find the length of the arc AB .

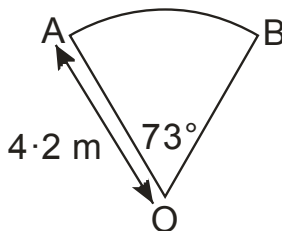

4. Change the formula $m=a+3b^2$ to b .

5. Solve the equation $2x^2+5x-9=0$.

Give your answer correct to 2 significant figures.

6. The marks of a group of students in their October test are listed below.

32 36 38 40 27 29 31 38 28 32 33 34

- (a) Calculate the median and the interquartile range.

The teacher arranges extra homework classes for the students before the next test in December.

In this test the median is 32 and the interquartile range is 7.

- (b) Make two appropriate comments comparing the marks in the October and December tests.

7. Two rectangular solar panels, A and B, are mathematically similar.

Panel A has a diagonal of 70 cm and an area of 3042 cm^2 .



A salesman claims that panel B, with a diagonal of 110 cm, will be triple the area of panel A.

Is this claim justified? **Show all you working.**

8. Two yachts leave from harbour H.
 Yacht A sails on a bearing of 041° for 70 kilometres and stops.
 Yacht B sails on a bearing of 149° for 65 kilometres and stops.

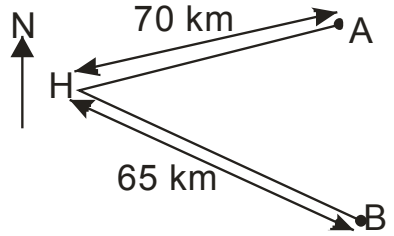

How far apart are the two yachts when they both have stopped?

Do not use a scale drawing.

9. Vector **a** has components $\begin{pmatrix} 3 \\ 0 \\ 2 \end{pmatrix}$ and vector **b** has components $\begin{pmatrix} -2 \\ 1 \\ 3 \end{pmatrix}$

Calculate the magnitude of $3\mathbf{a} - \mathbf{b}$.

10. A triangular paving slab has measurements as shown.
 Is the slab in the shape of a right angled triangle?

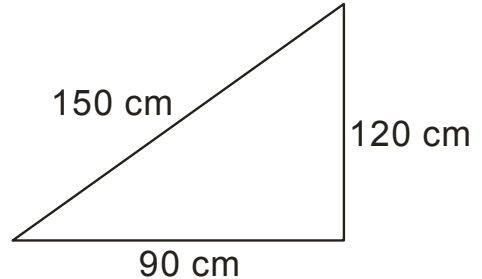

Show your working.

11. The diagram shows a pyramid.
 The base of the pyramid is an equilateral triangle of side 5 centimetres.
 The height of the pyramid is 8 cm.
 Calculate the volume of the pyramid.

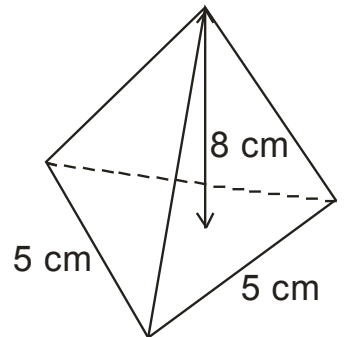

12. The graph below shows part of a parabola with equation of the form

$$y = (x + a)^2 + b$$

- (a) State the values of a and b .
 (b) The line PQ is parallel to the x -axis.

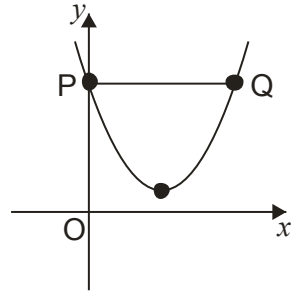

Find the coordinates of P and Q.

13. Part of the graph of $y = 5\sin x^\circ - 2$ is shown.

The graph cuts the x -axis at Q and R.

P is the maximum turning point.

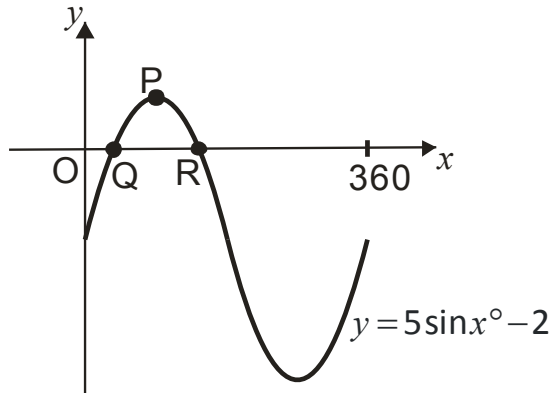

- (a) Write down the coordinates of P.
 (b) calculate the x - coordinates of Q and R.

14. The diagram shows the path of a flare after it is fired.

The height, h metres above sea level, of the flare, is given by $h = 24 + 5t - t^2$ where t is the number of seconds after firing.

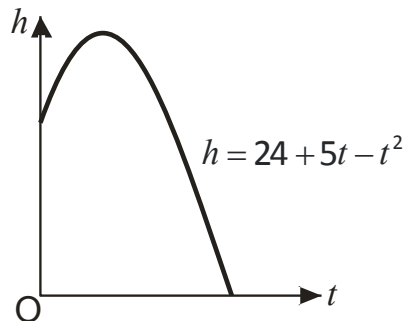

Calculate, **algebraically**, the time taken for the flare to enter the sea.

Paper D (Non-Calculator)

1. Evaluate: $1\frac{3}{4} + \frac{1}{2}$ of $1\frac{4}{5}$.
2. Solve the inequality: $2 - x > 3(x - 2)$.
3. Factorise $2p^2 + 9p - 5$.
4. The diagram represents a sphere.

The sphere has a diameter of 3 centimetres.

Calculate its volume.

Take $\pi = 3 \cdot 14$.

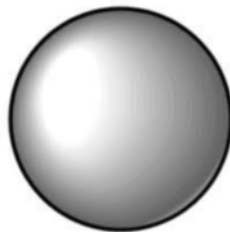

5. Solve algebraically the system of equations

$$3x - 4y = 20$$

$$4x + 5y = 6$$

6. Coffee is sold in small cups and large cups.

The two cups are mathematically similar in shape.

The small cup is 12 cm high and holds 54 millilitres.

The large cup is 16 cm high.

Calculate how many millilitres the large cup holds.

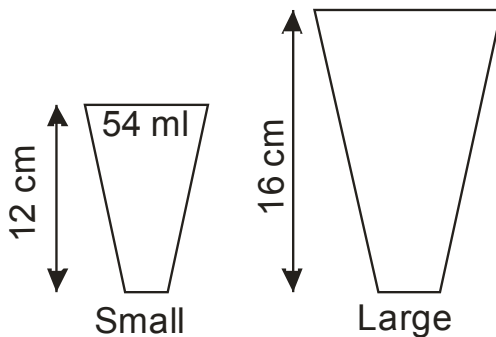

7. (a) Calculate the standard deviation of 1, 2, 2, 4 and 6.
(b) Hence state the standard deviation of 21, 22, 22, 24 and 26.
8. The temperature, in degrees Celsius, at mid-day in a seaside town and the sales, in pounds, of umbrellas are shown in the scattergraph (see over).
A line of best fit has been drawn.

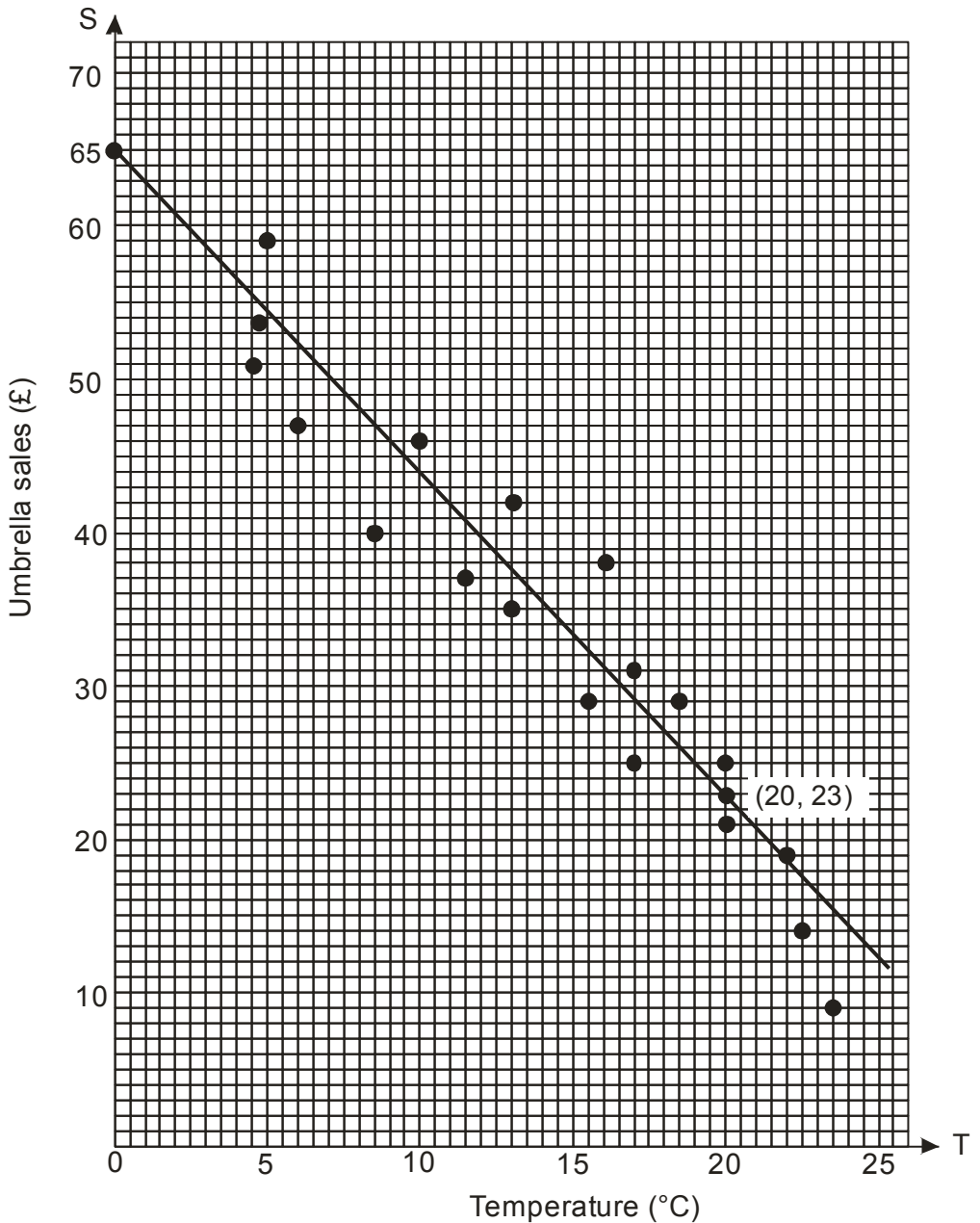

- (a) Find the equation of the line of best fit in terms of S and T .
- (b) **Use your answer to part (a)** to predict the sales for a day when the temperature is 30 degrees Celsius.

9. Cleano washing powder is on a special offer. Each box on special offer contains 15% more powder than the standard box.

A box on special offer contains 460 grams of powder.

How many grams of powder does the standard box hold?



10. The graph has an equation $y = \sin(x - a)^\circ$.

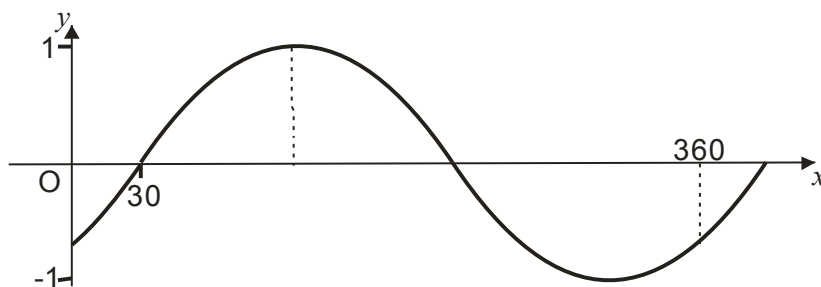

Write down the value of a .

11. Express $\frac{15}{\sqrt{3}}$ with a rational denominator.

Give your answer in its simplest form.

12. Brad is taking part in a cycling and running event. The course is 50 km long

(a) On Saturday he cycles the course in x hours.

Find his speed for the course in terms of x .

(b) On Sunday he takes 2 hours more to run the same course.

Find his speed in terms of x .

(c) Hence find an expression, in terms of x , for the difference in speeds between the cycling on Saturday and the running on Sunday.

13. William Watson's fast Foods use a logo based on parts of three identical parabolas.

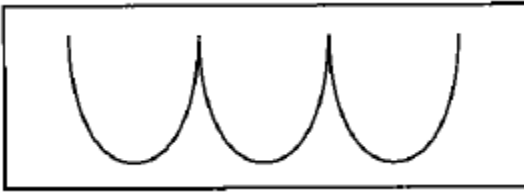

This logo is represented in the diagram below.

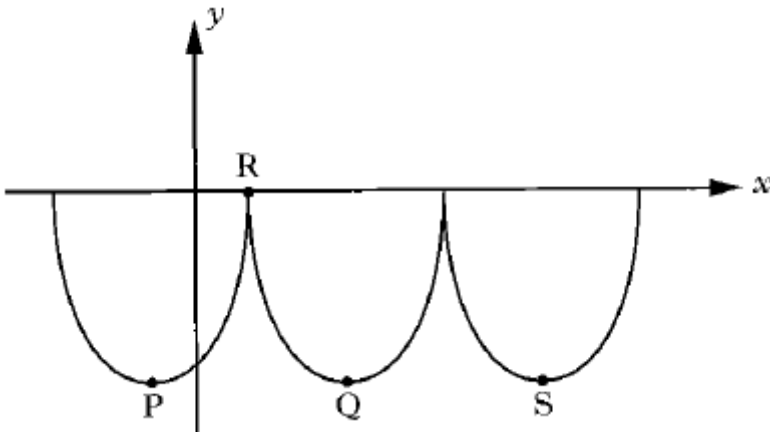

The first parabola has turning point P and equation $y = (x + 3)^2 - 14$.

- State the coordinates of P.
- If R is the point $(1, 0)$, find the coordinates of Q, the minimum turning point of the second parabola.
- Find the equation of the parabola with turning point S.

Paper D (Calculator)

1. The National Debt of the United Kingdom was calculated as

£1 492 719 214 375

Round this amount to four significant figures.

2. The diagram shows vectors s and t .

Find the components of $s + t$.

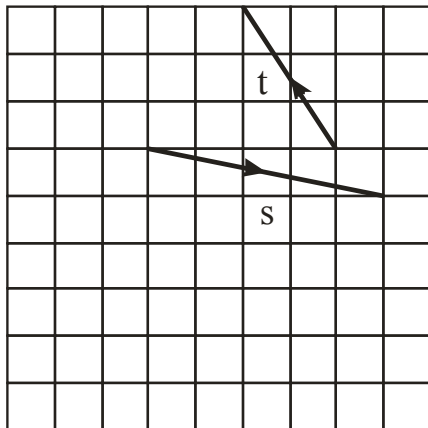

3. The diagram shows the graph of $y = -x^2$.

The point $(-4, k)$ lies on the graph.

Find the value of k .

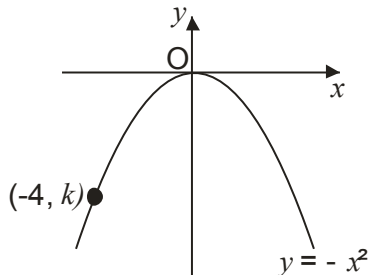

4. A health food shop produces cod liver oil capsules for its customers.

Each capsule is in the shape of a cylinder with hemispherical ends as shown.

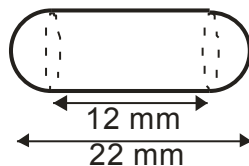

The total length of the capsule is 22 millimetres and the length of the cylinder is 12 millimetres.

Calculate the volume of one cod liver oil capsule.

5. OABCDEFG is a cube with side 4 units, as shown in the diagram.

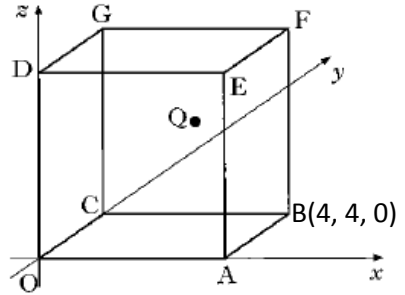

B has coordinates (4, 4, 0).

Q is the midpoint of face CBEF.

Write down the coordinates of G and Q.

6. Express in its simplest form $x^4 \times (x^2)^{-3}$.

7. A straight line is represented by the equation $3y + x = 12$.

(a) Find the gradient of this line.

(b) Write down the coordinates of the point where this line crosses the y -axis.

8. A pet shop manufactures protective dog collars.

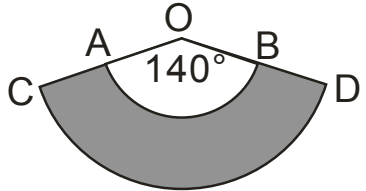

In the diagram the shaded area represents one of these collars.

AB and CD are arcs of circles with centres at O.

The radius, OA is 12 inches and the radius OC, is 16 inches.

Angle AOB is 140° .

Calculate the area of the collar.

9. Show that the equation $x(2 - 3x) = 5$ has no real roots.

10. In triangle PQR

- PQ = 6 cm
- PR = 8 cm
- Area of triangle PQR = 21 cm^2
- Angle QPR is obtuse

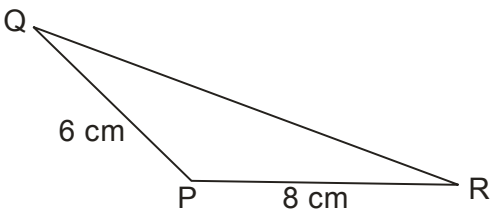

Calculate the size of angle QPR.

11. AD is a diameter of a circle, centre O.

B is a point on the circumference of the circle.

The chord BD is extended to a point C, outside the circle.

Angle BOA = 104° .

DC = 8 centimetres.

The radius of the circle is 6 centimetres.

Calculate the length of AC.

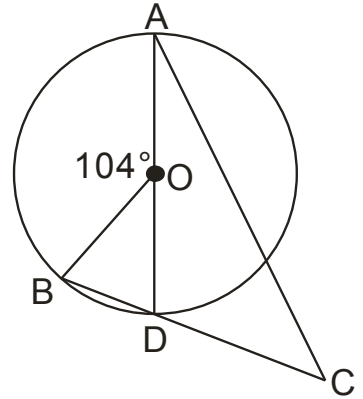

12. A right-angled triangle has dimensions, in centimetres, as shown.

Calculate the value of x .

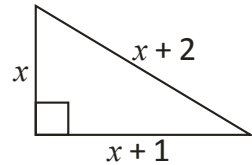

13. For safety reasons a building is supported by two wooden struts, represented by DB and DC in the diagram below.

Angle ABD = 62°

Angle BCD = 40°

BC is 4 metres

Calculate the height of the building represented by AD.

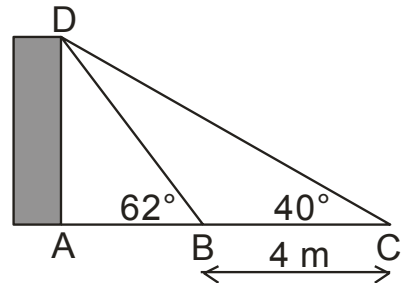

14. The government have decided that there are too many cars on the road.

They decide to reduce the amount of cars by 40% by the year 2060.

The government decided to encourage people to use public transport and cut the amount of cars by 14% every 10 years, starting in 2010.

Will the government have succeeded by 2060?

You must give a reason for your answer.

15. The depth of water, D metres, in a harbour is given by the formula

$$D = 4 + 1.5 \sin 30h^\circ$$

where h is the number of hours after midnight.

(a) Calculate the depth of the water at 6 am.

(b) Calculate the maximum difference in depth of the water in the harbour.

Do not use a trial and improvement method.

Paper E (Non-Calculator)

1. Evaluate: $1\frac{5}{6} \div \frac{5}{12}$
2. Multiply out the brackets and collect like terms: $(2x+5)(x^2-x+4)$
3. Two forces acting on a rocket are represented by vectors **a** and **b**.

$$a = \begin{pmatrix} -2 \\ 0 \\ 3 \end{pmatrix} \text{ and } b = \begin{pmatrix} 3 \\ -4 \\ 1 \end{pmatrix}$$

Calculate $|a+b|$, the magnitude of the resultant force.

Leave your answer as a surd.

4. Solve the equation: $6x^2 + 13x - 5 = 0$.
5. Express $\frac{2}{\sqrt{6}}$ with a rational denominator in its simplest form.

6. Teams in a quiz answer questions on film and sport.

This scattergraph shows the scores of some of the teams.

A line of best fit is drawn as shown.

- (a) Find the equation of this straight line.
- (b) Use the equation to estimate the Sport Score for a team with a Film Score of 6.

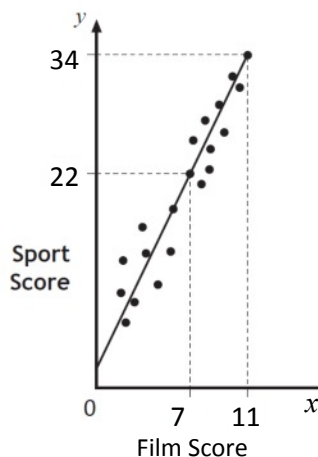

7. Change the subject of the formula $p = \frac{4\sqrt{q}}{r}$ to q .

8. (a) Multiply out the brackets and simplify: $x^{\frac{3}{2}}(x^{\frac{1}{2}} + x^{-\frac{1}{2}})$.
- (b) Find the exact value of this expression when $x = 6$.
9. A parabola has equation $y = x^2 + 4x + 2$.
- (a) Write the equation in the form $y = (x + a)^2 + b$.
- (b) Sketch the graph of $y = (x + a)^2 + b$, showing the coordinates of the turning point and the point of intersection with the y-axis.
10. Colin and Jane visit a music shop. Colin buys 2 CDs and 3 DVDs. The total cost of this is £40.
- (a) Write down an equation to illustrate this information.
- (b) Jane buys 5 CDs and 2 DVDs.
- The total cost of this is £56.
- Write down an equation to illustrate this information.
- (c) Find the cost of a CD and the cost of a DVD.
11. Express: $\frac{5}{x+1} - \frac{3}{x-2}$, $x \neq -1, x \neq 2$ as a single fraction in its simplest form.

12. A cylindrical pipe has water in it as shown.
- The depth of the water at the deepest point is 6 centimetres.
- The width of the water surface, AB, is 16 centimetres.
- The radius of the pipe is r centimetres. The distance from the centre, O, of the pipe to the water surface is x centimetres.

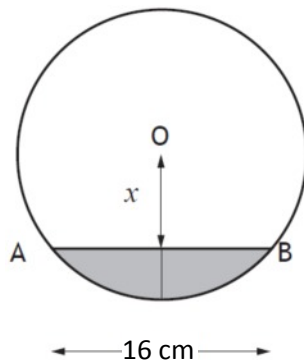

- (a) Write down an expression for x in terms of r .
- (b) Calculate r , the radius of the pipe.

Paper E (Calculator)

- Beth normally cycles a total distance of 64 miles per week.
She increases her distance by 14% each week for the next three weeks.
How many miles will she cycle in the third week?
- There are 5×10^6 platelets per millilitre of blood.
On average, a person has 2.9 litres of blood.
On average, how many platelets does a person have in their blood?
Give your answer in scientific notation.

- In the diagram, OABCDE is a regular hexagon with centre M.

Vectors **a** and **b** are represented by \overrightarrow{OA} and \overrightarrow{OB} respectively.

- Express \overrightarrow{AB} in terms of **a** and **b**.
- Express \overrightarrow{OC} in terms of **a** and **b**.

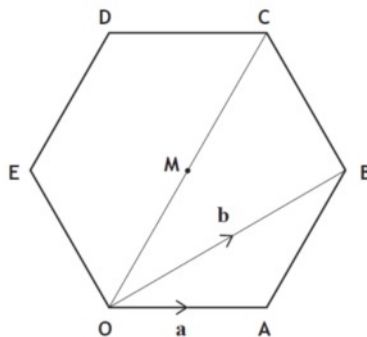

- The graph with equation $y = kx^2$ is shown.
The point $(2, -32)$ lies on the graph.
Determine the value of k .

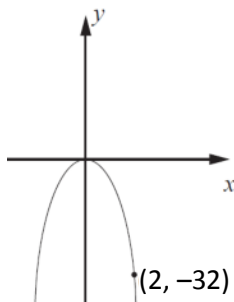

- In triangle MNP, MP = 4 m,
MN = 6 cm and
angle PMN = 115° .
Calculate the length of PN.

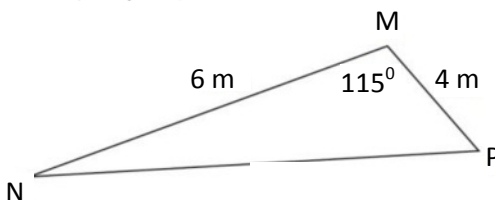

6. A child's toy is in the shape of a hemisphere with a cone on top, as shown in the diagram.

The toy is 14 centimetres wide and 18 centimetres high.

Calculate the volume of the toy. Give your answer correct to 2 significant figures.

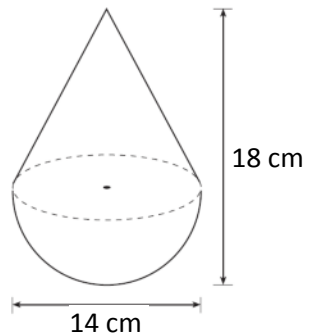

7. This year Adèle paid £276 for T in the Park tickets.

This is an increase of 15% on last year's payment.

How much did Adèle pay last year?

8. A frozen food company uses machines to pack sprouts into bags.

A sample of six bags is taken from Machine A and the number of sprouts in each bag is counted.

The results are shown: 32 30 35 33 35 33

(a) Calculate the mean and standard deviation of this sample.

(b) Another sample of six bags is taken from Machine B.

This sample has a mean of 35 and a standard deviation of 2.7.

Write down two valid comparisons between the samples.

9. Screenwash is available in two different sized bottles, 'Mini' and 'Maxi'.

The bottles are mathematically similar.

Calculate the volume of the 'Maxi' bottle.

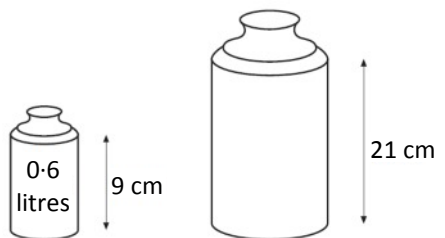

10. Part of the graph of $y = a \sin x^\circ + b$ is shown below.

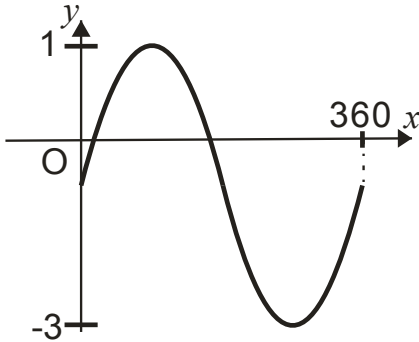

- (a) Explain how you can tell from the graph that $a = 2$ and $b = -1$
- (b) Calculate the x -coordinates of the points where the graph cuts the x -axis.

11. A cone is formed from a paper circle with a sector removed as shown.
The radius of the paper circle is 50 centimetres.
Angle AOB is 105° .

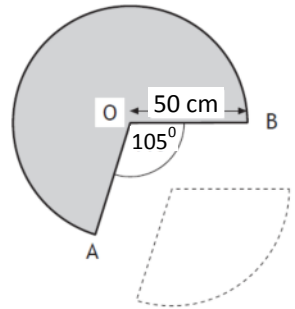

- (a) Calculate the area of the sector removed from the circle.
- (b) Calculate the circumference of the base of the cone.
12. Find the range of values of p such that the equation $px^2 + 2x - 4 = 0$, $p \neq 0$, has no real roots.

Paper F (Non-Calculator)

1. Evaluate: $4\frac{1}{4} - 1\frac{3}{5}$.
2. Expand and simplify: $(2x - 3)(2x^2 - 5x + 2)$.
3. Change the subject of the formula to d : $a = \frac{5}{cd^2}$.

4. The diagram shows a tiling of congruent triangles.

Vectors \mathbf{u} and \mathbf{v} are represented by \overrightarrow{AB} and \overrightarrow{AF} respectively.

(a) Express \overrightarrow{AD} in terms of \mathbf{u} and \mathbf{v} .

(b) Express \overrightarrow{EC} in terms of \mathbf{u} and \mathbf{v} .

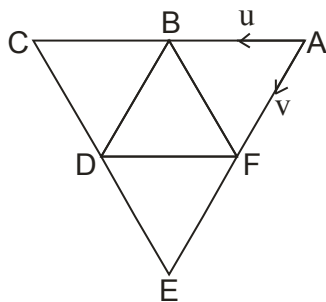

5. In the diagram

- O is the centre of the circle
- PQ is the diameter
- PQR is a straight line
- RS is a tangent to the circle at S
- Angle QPS is 32°

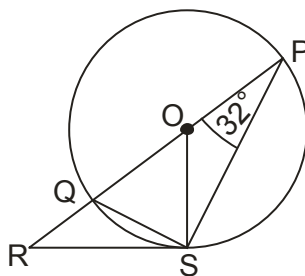

Calculate the size of angle QRS.

6. Express $\frac{6x^2 - 3x}{2x^2 + 9x - 5}$ in its simplest form.
7. Evaluate $9^{\frac{3}{2}}$.
8. Simplify $\frac{5}{a+1} + \frac{2}{a-2}$.

9. The diagram shows part of the graph of

$$y = 3 + 2x - x^2.$$

- (a) Find the coordinates of A and B
- (b) State the equation of the axis of symmetry of the graph.
- (c) Hence, find the maximum value of $y = 3 + 2x - x^2$.

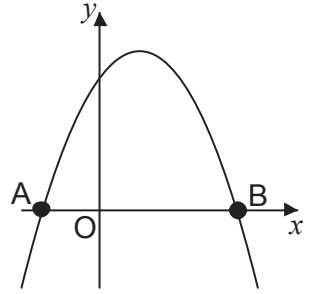

10. The graph below shows two straight lines

- $y = 2x + 3$
- $x + 3y = 16$

The lines intersect at the point P.

Find, **algebraically**, the coordinates of P.

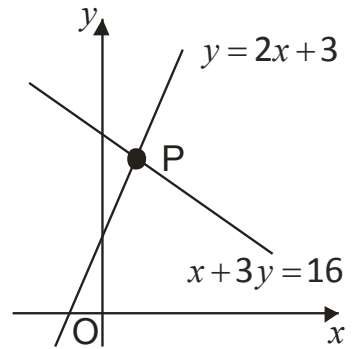

11. Part of the graph of $y = a \sin bx^\circ$ is shown in the

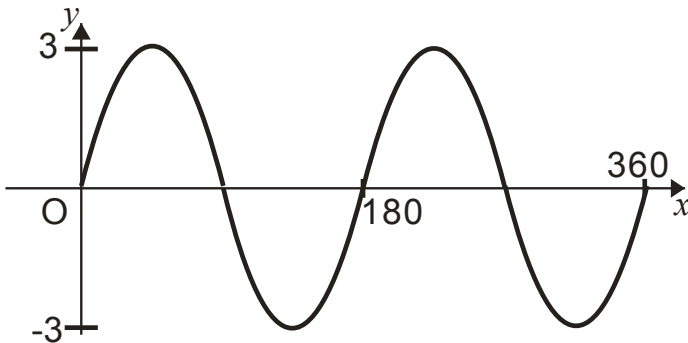

State the values of a and b .

12. In the triangle ABC, show that $\cos B = \frac{7}{8}$.

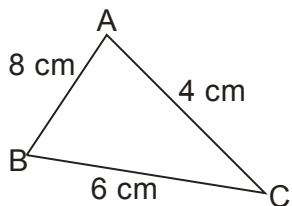

13. The rectangle has length $3\sqrt{5}$ centimetres and breadth $\sqrt{10}$ centimetres.

Calculate the area of the rectangle.

Express your answer as a surd in its simplest form.

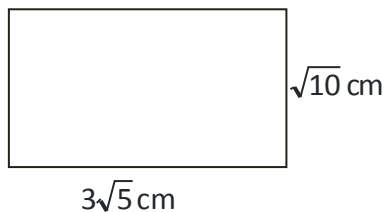

14. Prove that the roots of the equation $3x^2 + 8x + 2 = 0$ are real.

Paper F (Calculator)

1. Alistair buys an antique chair for £700.

It is expected to increase in value at the rate of 4.1% each year.

How much is it expected to be worth in 3 years?

2. A footballer scored the following number of goals in a series of tournaments.

15 12 13 17 13

(a) For this sample calculate the mean and standard deviation.

The following season the team appoints a new coach. A similar series of matches produces a mean of 12 and a standard deviation of 5.6.

(b) Make two valid comparisons about the performance of the player under the new coach.

3. The diagram shows a cuboid OPQRSTUV relative to the coordinate axes.

P is the point (7, 0, 0), Q is (7, 4, 0) and U is (7, 4, 5).

M is the midpoint of OR.

N is the point on UQ such that $UN = \frac{1}{5}UQ$.

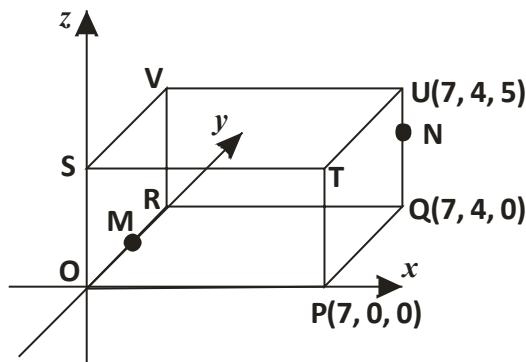

State the coordinates of M and N.

4. Find the equation of the straight line shown in the diagram.

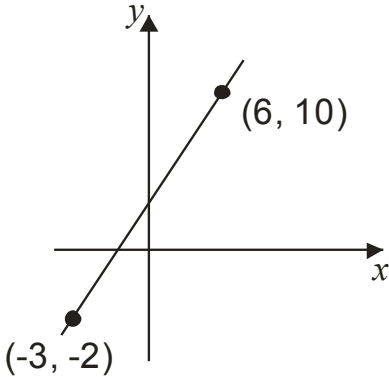

5. A spiral staircase is being designed.

Each step is made from a sector of a circle as shown.

The radius is 1.8 metres.

Angle BAC is 38° .

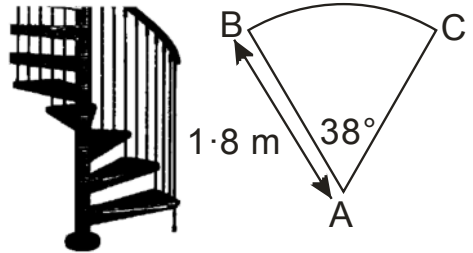

For the staircase to pass safety regulations, the arc BC must be at least 1.1 metres. Will the staircase pass safety regulations?

6. A glass ornament is in the shape of a cone partly filled with coloured water.

The cone is 26 centimetres high and has a base diameter 32 centimetres.

The water is 22 centimetres deep and measures 8 centimetres across the top.

What is the volume of the water?

Give your answer correct to 2 significant figures.

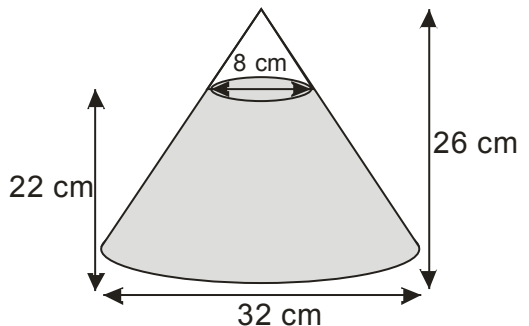

7. The price for Paul's summer holiday is £979.44.

The price includes a 6% booking fee.

What is the price of his holiday without the booking fee?

8. A heavy metal beam, AB, rests against a vertical wall as shown.

The length of the beam is 7 metres and it makes an angle of 64° with the ground.

A cable, CB, is fixed to the ground at C and is attached to the top of the beam at B.

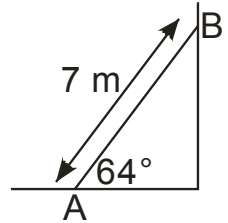

The cable makes an angle of 28° with the ground.

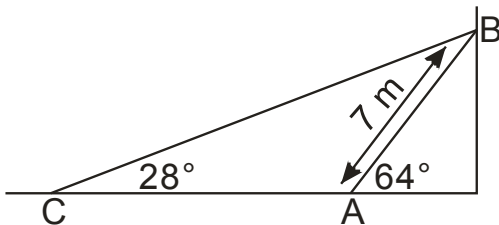

Calculate the length of cable CB.

9. A necklace is made of beads which are mathematically similar.

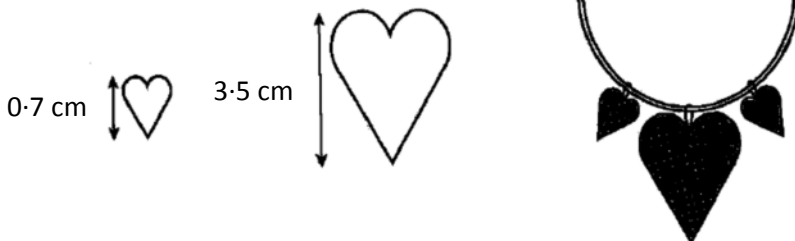

The height of the smaller bead is 0.7 centimetres and its area is 0.8 square centimetres. The height of the larger bead is 3.5 centimetres. Find the area of the larger bead.

10. Paving stones are in the shape of a rhombus.

The side of each rhombus is 50 centimetres long.

The obtuse angle is 112° .

Find the area of one paving stone.

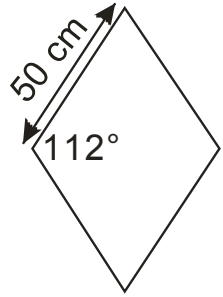

11. $f(x) = 3\cos x$, $0 \leq x \leq 360$.

(a) Find $f(180)$

(b) If $f(t) = 1.2$, find two possible values of t .

12. A tanker delivers oil to garages.

The tanker has a circular cross-section as shown.

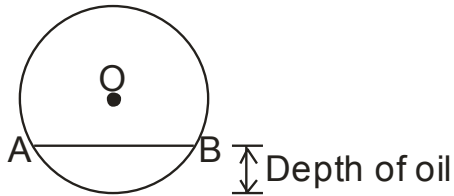
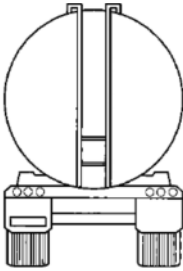

The radius of the circle, OA is 1.5 metres.

The width of the surface of the oil, represented by AB in the diagram, is 2.2 metres.

Calculate the depth of oil in the tanker.

13. Triangles PQR and STU are mathematically similar.

The scale factor is 3 and PR corresponds to SU .

(a) Show that $x^2 - 9x + 8 = 0$.

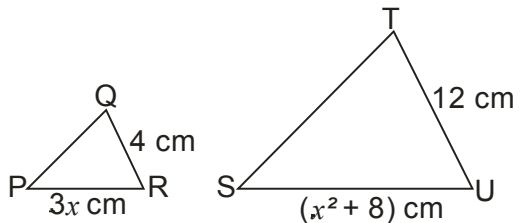

(b) Given that QR is the shortest side of triangle PQR , find the value of x .



Auchmuty Model Paper A1 Non-Calculator Answers

1. 4
2. $3x^3 - 5x^2 + 7x + 3$
3. $3\sqrt{6}$
4. $x = -\frac{2}{3}$, $x = \frac{1}{2}$
5. $\frac{4\sqrt{10}}{5}$
6. (a) $y = 2x + 3$ (b) 17
7. $b = \sqrt{\frac{4a}{c}}$
8. (a) $x^3 + 1$ (b) 65
9. (a) $(x - 3)^2 + 5$

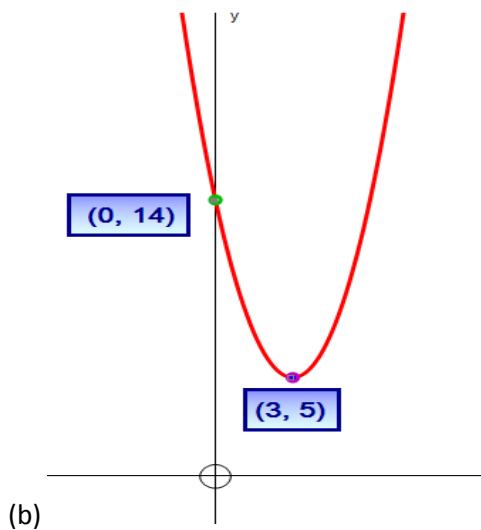

10. (a) $3x + 2y = 33$ (b) $4x + 3y = 47$ (c) CD - £5 , DVD - £9
11. $\frac{x-13}{(x+2)(x-3)}$
12. (a) $x = r - 4$ (b) $r = 8.125$

Auchmuty Model Paper A2 Calculator Answers

1. 67.4
2. 2.48×10^8
3. (a) $\underline{b} - \underline{a}$
(b) $2\underline{b} - 2\underline{a}$
4. $K = -3$
5. 8.8
6. 680 cm^3
7. £240
8. (a) Mean = 26. Standard deviation = 2.4
(b) On average, bags from Machine B has fewer sprouts.
The number of sprouts in bags from Machine B varies more.
9. 6.25 Litres
10. (a) $a = 4, b = 1$ (b) $104.5^\circ, 255.5^\circ$
11. (a) 981.25 cm^2 (b) 123 cm
12. $p > 1$



Auchmuty Model Paper B1 Non-Calculator Answers

- $2\frac{9}{10}$
- $4x^3 - 16x^2 + 19x - 6$
- $q = (Vr)^2$
- (a) $2\underline{u} + 2\underline{v}$
(b) $-\underline{u} + 2\underline{v}$
- $\angle QRS = 42^\circ$
- $\frac{2y}{y-1}$
- 4
- $\frac{5m-2}{m(m-1)}$
- (a) A(-2, 0) B(4, 0)
(b) $x = 1$
(c) 9
- (2, 4)
- $a = 6, b = 6$
- $\frac{11}{16}$
- $24\sqrt{2}$
- $b^2 - 4ac = 25 > 0$ so 2 real and distinct roots

Auchmuty Model Paper B2 Calculator Answers

- £574.57
- (a) Mean = 9, standard deviation = 4.1

(b) After a New coach :- on average, the number of goals scored increased; the number of goals scored varied less.
- M(0, 3, 0) N(8, 6, 3)
- $y = 2x + 1$
- Yes, Arc = 1.12 m > 0.8 m
- Volume water = 2800 cm^3
- £850
- CB = 18.1 m
- Large Area = 14.4 cm^2
- 2318 cm^2
- (a) $f(270) = -4$
(b) $t = 11.5^\circ, 168.5^\circ$
- Depth = 0.42 m
- (a) $2 \times 4x = x^2 + 7 \Rightarrow 8x = x^2 + 7 \Rightarrow x^2 - 8x + 7 = 0$
(b) $x = 1$ and $x = 7$ but if QR = 5cm is smallest side then $x = 7$.



Auchmuty Model Paper C1 Non-Calculator Answers

- $\frac{6}{17}$
- $3(a+2)(a-2)$
- $f(-2) = 3$
- $x = -\frac{11}{5}$
- $4\sqrt{2}$
- $(x+4)^2 - 9$
- (a) $24x + 6y = 60$
(b) $20x + 10y = 40$
(c) $17 \times 3 - 13 \times 2 = 25$
- 142°
- $g = \frac{2}{3}h - 4$
- $\frac{3}{4}a + \frac{1}{2}b$
- a
- $\frac{8}{\sin 150} = \frac{4}{\sin B} \Rightarrow 8\sin B = 4\sin 150 \Rightarrow 8\sin B = 2 \Rightarrow \sin B = \frac{1}{4}$; use $\sin 150 = \sin 30 = \frac{1}{2}$
- $\frac{\sin^2 A}{1 - \sin^2 A} = \frac{\sin^2 A}{\cos^2 A} = \tan^2 A$

Auchmuty Model Paper C2 Calculator Answers

- 1.536×10^{-1}
- $x^3 - 4x^2 + 4x$
- Arc = 5.3 m
- $b = \sqrt{\frac{m-a}{3}}$
- $x = 1.2$, $x = -3.7$
- (a) median = 32.5 Interquartile range = 7
(b) December's median is higher so the test scores are higher on average.
December's interquartile range is the lower so December's test scores vary less.
- Claim is unjustified as Area factor is 2.47 which is less than 3.
- 109 km
- $3\underline{a} - \underline{b} = \begin{pmatrix} 11 \\ -1 \\ 3 \end{pmatrix}$; $|3\underline{a} - \underline{b}| = \sqrt{131}$
- Longest side: $150^2 = 22500$
Shortest side: $120^2 = 14400$
Middle side: $90^2 = 8100$
 $81000 + 144000 = 22500 = \text{longest side squared.}$

By converse of Pythagoras, triangle is right-angled.
- $V = 28.9 \text{ cm}^3$
- (a) $a = -4$, $b = 2$
(b) $P(0, 18)$ $Q(8, 18)$
- (a) $P(90^\circ, 3)$ (b) $x = 23.6^\circ, 156.4^\circ$
- Time is 8 seconds



Auchmuty Model Paper D1 Non-Calculator Answers

- $2\frac{13}{20}$
- $x < 2$
- $(2p - 1)(p + 5)$
- 113.04 cm^3
- $x = 4; y = -2$
- 128 ml
- (a) $\text{Mean} = 3; S.D. = 2$
(b) 2
- (a) $S = -2.1T + 65$
(b) £2
- 400 grams
- $a = 30$. i.e. $y = \sin(x - 30)^\circ$
- $5\sqrt{3}$
- (a) $\frac{50}{x}$
(b) $\frac{50}{x+2}$
(c) $\frac{100}{x(x+2)}$
- (a) $P(-3, -14)$
(b) $Q(5, -14)$
(c) S is $(13, -14)$ so $y = (x - 13)^2 - 14$

Auchmuty Model Paper D2 Calculator Answers

- £1 493 000 000 000
- $\binom{3}{2}$
- $k = -16$
- $1465.33 \dots \text{ mm}^3$ (using 3.14 for π)
- $G(0,4,4); Q(2,4,2)$
- x^{-2} or $\frac{1}{x^2}$
- (a) $m = -\frac{1}{3}$
(b) (0,4)
- $136.764 \dots \text{ inches}^2$ (using 3.14 for π)
- $b^2 - 4ac = -54$ so no real roots since $-54 < 0$
- 119°
- 18.1 cm (to 3 sig figs)
- $x = 3$
- 6.06 m (to 3 sig figs)
- Car use dropped by 53%. $53\% > 40\%$ so yes government have succeeded.
- (a) 4 m
(b) 5.5 m and 2.5 m



Auchmuty Model Paper E1 Non-Calculator Answers

1. $4\frac{2}{5}$
2. $2x^3 + 3x^2 + 3x + 20$
3. $\sqrt{33}$
4. $x = \frac{1}{3}, x = -\frac{5}{2}$
5. $\frac{\sqrt{6}}{3}$
6. (a) $y = 3x + 1$ (b) 19
7. $q = \left(\frac{pr}{4}\right)^2$ or $q = \frac{p^2r^2}{16}$
8. (a) $x^2 + x$ (b) 42
9. (a) $y = (x + 2)^2 - 2$

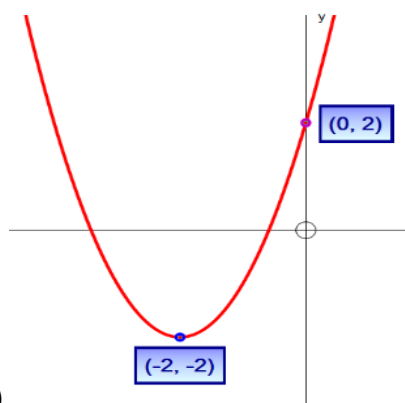

- (b)
10. (a) $2c + 3d = 40$ (b) $5c + 2d = 56$ (c) CD: £8, DVD: £8
 11. $\frac{2x-13}{(x+1)(x-2)}$
 12. (a) $r - 6$ (b) $\frac{25}{3}$ cm or $8\frac{1}{3}$ cm
 - 13.

Auchmuty Model Paper E2 Calculator Answers

1. 94.8 miles
2. 1.45×10^{10}
3. (a) $-a + b$
(b) $-2a + 2b$
4. $k = -8$
5. 8.5 m
6. 1300 cm^3
7. £240
8. (a) Mean = 33, S.D. = 1.9
(b) **Machine B** has a higher mean so it **packs more sprouts on average.**
Machine B's S.D. is higher so its **pack size varies more.**
9. 7.62 Litres (3 sig figs)
10. (a) $a = 2, b = -1$
(b) $x = 30$ and $x = 150$
11. (a) 2289.6 cm^2
(b) 222.4 cm
12. $p < \frac{1}{4}$



Auchmuty Model Paper F1 Non-Calculator Answers

- $2\frac{13}{20}$
- $4x^3 - 16x^2 + 19x - 6$
- $d = \sqrt{\frac{5}{ac}}$
- (a) $\mathbf{u + v}$
(b) $\mathbf{-2v + 2u}$
- 26°
- $\frac{3x}{x+5}$
- 27
- $\frac{7a-8}{(a+1)(a-2)}$
- (a) $A(-1,0), B(3,0)$
(b) $x = 1$
(c) 4
- (1,5)
- $a = 3, b = 2$
- $\cos B = \frac{6^2+8^2-4^2}{2 \times 6 \times 8}$ simplifying until you arrive at $\frac{7}{8}$
- $15\sqrt{2}$
- $b^2 - 4ac = 40$ $40 \geq 0$ so 2 real (and distinct) roots

Auchmuty Model Paper F2 Non-Calculator Answers

- £789.68
- (a) Mean = 14. S.D. = 2
(b) Mean went down so the **number of goals scored was less on average** under new coach.
S.D. went up so the **number of goals scored varied more** under new coach.
- $M(0,2,0)$ and $N(7,4,4)$
- $y = \frac{4}{3}x + 2$ or $y - 10 = \frac{4}{3}(x - 6)$
- Arc length = 1.19 m. $1.19 > 1.1$ so it will pass regulations.
- 6900 cm^3 (2 sig figs)
- £920.67
- 13.4 m
- 20 cm^2
- 4636 cm^2
- (a) -3
(b) $t = 66.4^\circ, t = 293.6^\circ$
- 0.5 m
- (a) $3(3x) = x^2 + 8$
 $9x = x^2 + 8$
 $x^2 - 9x + 8 = 0$
(b) $x = 8$